

**VACUUM PUMP**



**GENERAL  
EUROPE  
VACUUM S.r.l.**  
*Tecnologie Del Vuoto*

## **Operating Manual**



# VACUUM PUMP

## I. Pump components

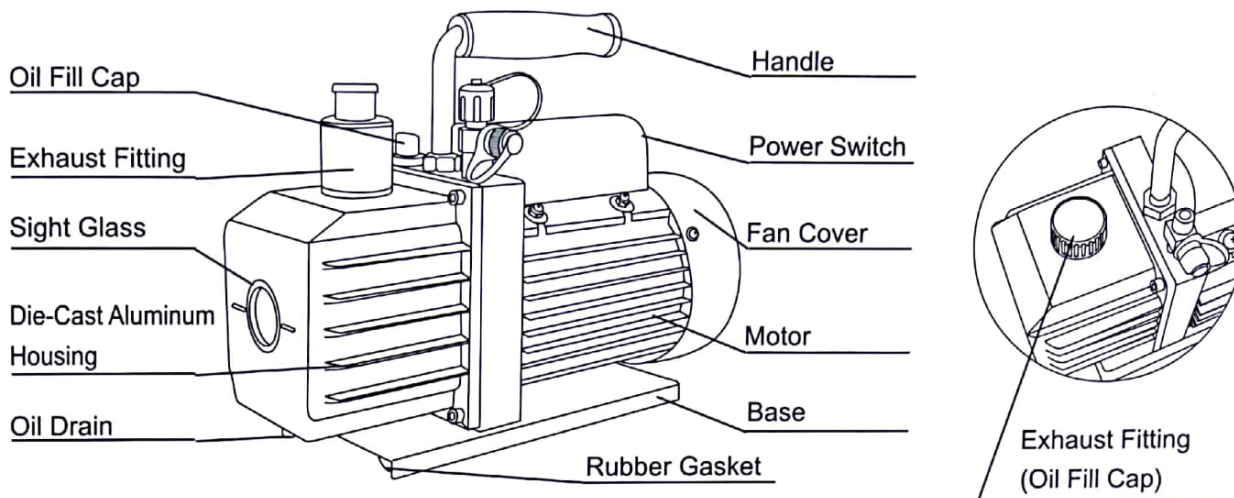

## II. Operating Manual

### 1. Before using your vacuum pump

In all cases, motors are designed for operating voltages plus or minus 10% of the normal rating. Single voltage motors are supplied fully connected and ready to operate.

(1) Check to be sure the voltage and frequency at the outlet match the specifications on the pump motor decal. Check the ON-OFF switch to be sure it is in the OFF position before you plug the pump into an outlet. Remove and discard the exhaust plug from the end of the pump's handle.

(2) The pump is shipped without oil in the reservoir. Before starting the pump, fill it with oil. Remove the OIL FILL cap and add oil until oil just shows in the bottom of the sight glass. The approximate oil capacity of the pump is 220~380ml (reference the technical data).

(3) Replace the OIL FILL cap and remove the cap from one of the inlet ports. Turn the motor switch to ON. When the pump runs smoothly, replace the cap on the inlet port. This may take from two to 30 seconds depending on the ambient temperature. After the pump runs for approximately one minute, check the sight glass for proper oil level should be even with the sight glass OIL LEVEL line. Add oil if necessary.

Note: When the pump is running, the oil level should be even with the line on the sight glass. Underfilling will result in poor vacuum performance. Over filling can result in oil blowing from the exhaust.



## VACUUM PUMP

2. To shut down your pump after use

To help prolong pump life and promote easy starting, follow these procedures for shutdown.

(1) Close the manifold valve between the pump and the system.

(2) Remove the hose from the pump inlet.

(3) Cap the inlet port to prevent any contamination or loose particles from entering the port.

### III. To maintain your high vacuum pump

1. Vacuum pump oil:

The condition and type of oil used in any high vacuum pump are extremely important in determining the ultimate attainable vacuum. We recommend the use of High Vacuum Pump Oil. This oil has been specifically blended to maintain maximum viscosity at normal running temperatures and to improve cold weather starts.

2. Oil Change Procedure

(1) Be sure the pump is warmed up.

(2) Remove the OIL DRAIN cap. Drain contaminated oil into a suitable container and dispose of properly. Oil can be forced from the pump by opening the inlet and partially blocking the exhaust with a cloth while the pump is running. Do not operate the pump for more than 20 seconds using this method.

(3) When the flow of oil has stopped, tilt the pump forward to drain residual oil.

(4) Replace the OIL DRAIN cap. Remove the OIL FILL cap and fill the reservoir with new vacuum pump oil until the oil just shows at the bottom of the sight glass. The approximate oil capacity of the pump is 220~380ml (reference the technical data).

(5) Be sure the inlet ports are capped, then turn on the pump. Allow it to run for one minute, then check the oil level. If the oil is below the sight glass OIL LEVEL line, add oil slowly (with the pump running) until the oil reaches the OIL LEVEL line. Replace the OIL FILL cap, making sure the inlet is capped and the drain cap is tight.

(6) a) If the oil is badly contaminated with sludge that forms when water is allowed to collect in the oil, you may need to remove the oil reservoir cover and wipe it out.

## VACUUM PUMP

---

b) Another method of dealing with heavily contaminated oil is to force the oil from the pump reservoir. To do this, allow the pump to run until it is warmed up. While the pump is still running, remove the oil drain cap. Slightly restrict the exhaust. This will back-pressure the oil reservoir and force the oil from it, carrying more contaminants. When the oil ceases to flow, turn off the pump.

Repeat this procedure as required until the contamination is removed

Replace the OIL DRAIN cap and refill the reservoir to the proper level with fresh pump oil.

### **IV. Troubleshooting Guide**

Your pump has been designed for dependable use and long life. If something should go wrong, however, the following guide will help you get pump back into service as quickly as possible.

If disassembly of the pump is required, please check your warranty. The warranty may be voided by misuse or customer tampering which results in the pump being inoperable.

#### 1. Failure To Start

Check the line voltage. The pumps are designed to start at  $\pm 10\%$  line voltage (loaded) at 32°F. At extremes, however, switching between the start and run windings may occur.

#### 2. Oil leakage

(1) Be sure the oil is not a residual accumulation from spillage, etc.

(2) If leakage exists, the module cover gasket or the shaft seal may need replacing.

If leakage exists in the area of the oil drain plug, you may need to reseal the plug using a commercial pipe thread sealer.

#### 3. Failure To Pull A Good Vacuum

(1) Be sure the vacuum gauge and all connections are in good condition and leakfree. You can confirm leakage by monitoring the vacuum with a thermistor gauge while applying vacuum pump oil at connections or suspected leak points. The vacuum will improve briefly while the oil is sealing the leak.

(2) Be sure the pump oil is clean. A badly contaminated pump may require several oil flushes.

(3) Be sure the oil is at the proper level. For maximum pump operation, the oil

## VACUUM PUMP

must be even with the OIL LEVEL line on the sight glass when the pump is running. Do not overfill----operating temperatures will cause the oil to expand, so it will appear at a higher level than when the pump is not running. To check the oil level, stop the pump, start the pump with the inlet capped, Check the oil level in the sight glass. Add oil if necessary.

### V. Technical Parameter

Type	4 GP1	3 GP2	4 GP2	6 GP2
Voltage	220V/50Hz	220V/50Hz	220V/50Hz	220V/50Hz
Capacity	4.5m <sup>3</sup> /h	3m <sup>3</sup> /h	4.5m <sup>3</sup> /h	6m <sup>3</sup> /h
Ultimate Vacuum (mbar)	0.05	0.003	0.003	0.003
Stages	1	2	2	2
Motor	1/4 HP	1/4 HP	1/3 HP	1/2 HP
Intake Ports	1/4 "Flare			
Oil Capacity	310ml	200ml	250ml	330ml
Dimensions(mm)	285x124x230	308x124x230	315x124x240	335x138x250
Net Weight	7.1kg	7.5kg	8.6kg	11.4kg



## VI.Exploded Drawing

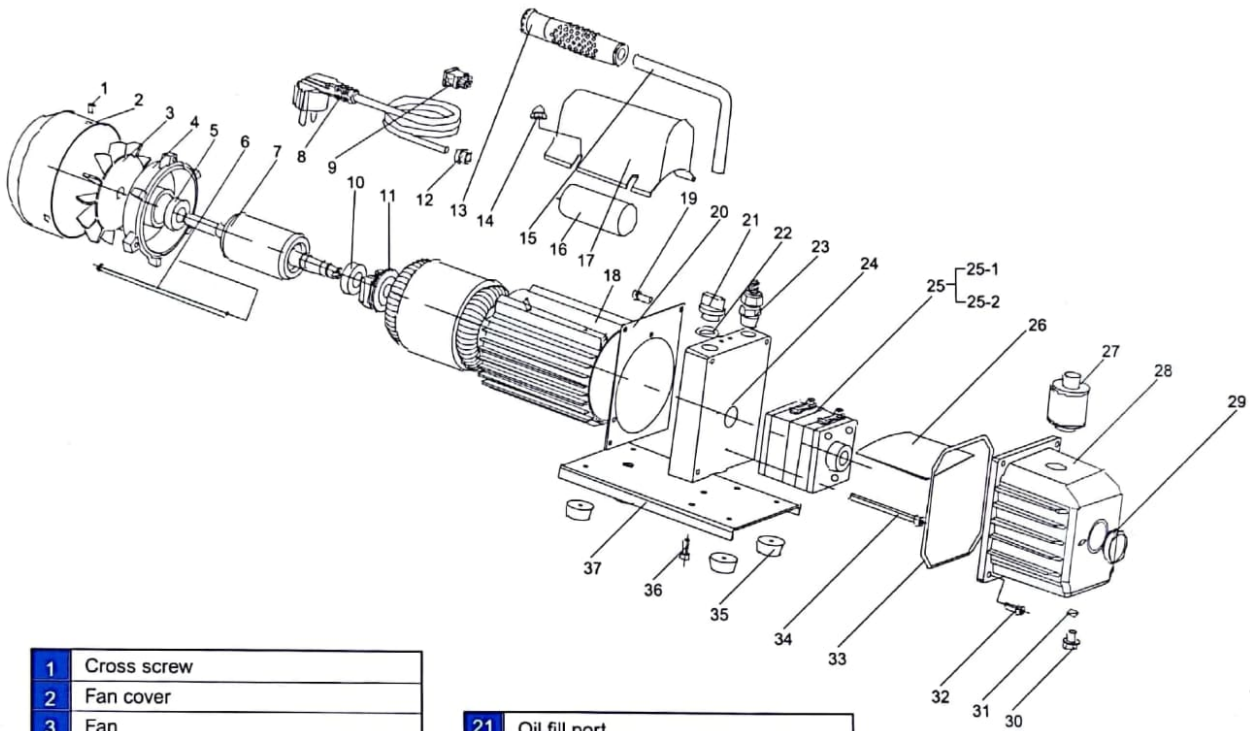

1	Cross screw
2	Fan cover
3	Fan
4	Motor cover
5	Bearing
6	Cross screw
7	Motor rotor
8	Power supply cords
9	Power switch
10	Bearing
11	Centrifugal switch
12	Insulating bushing
13	Handle slipcover
14	Nut
15	Handle
16	Capacitor
17	Junction box
18	Motor hull
19	Screw
20	Trestle cover board

21	Oil fill port		
22	Seal		
23	Inlet fitting		
24	Trestle		
25	Pump body	25-1	Rotary-vane
		25-2	Rotary-vane spring
26	Cap board		
27	Exhaust fitting		
28	Die cast aluminum housing		
29	Sight glass		
30	Oil cap		
31	Seal		
32	Screw		
33	Seal		
34	Screw		
35	Rubber foot		
36	Screw		
37	Base		