

Pompa tipo GS 6 - 10

Pump type GS 6 - 10

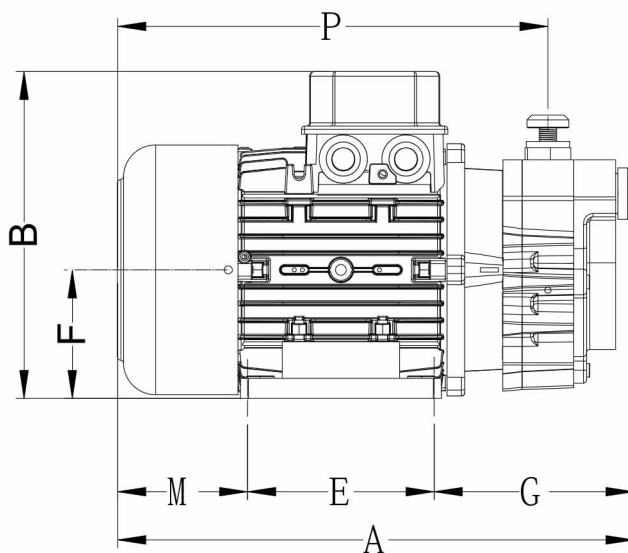
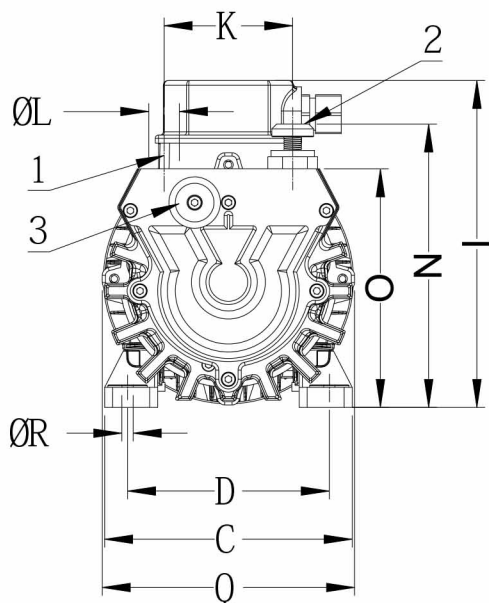

- 1 Aspirazione
- 2 Mandata
- 3 Filtro aspirazione

- 1 Suction
- 2 Discharge
- 3 Inlet filter

	Dimensioni (mm) Dimension (mm)															
GS	A	B	C	D	E	F	G	I	K	L	M	N	O	P	Q	R
6	321	203	154	125	116	80	124	55	80	½" GAS	81	176	148	267	157	9,5
10	332	203	154	125	116	80	137	55	80	½" GAS	81	176	148	273	157	9,5

Disponibile anche nella versione compressore
 Pump is available also as compressor version

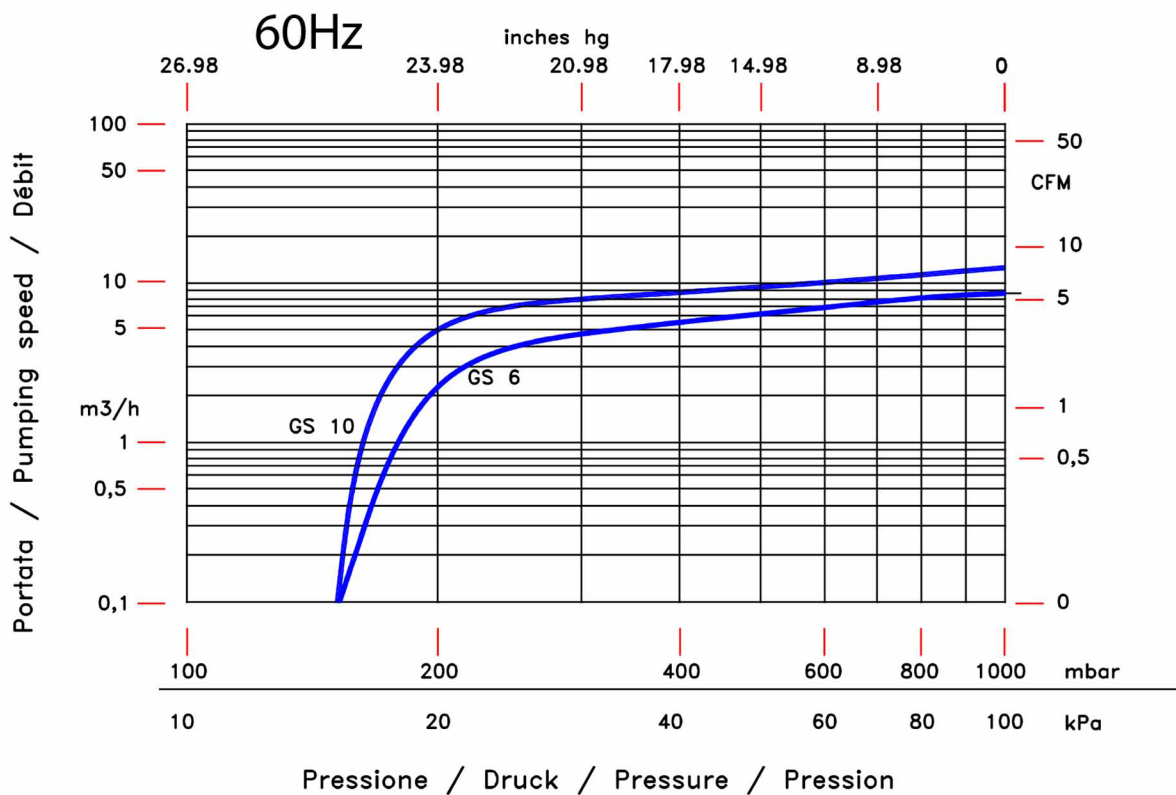
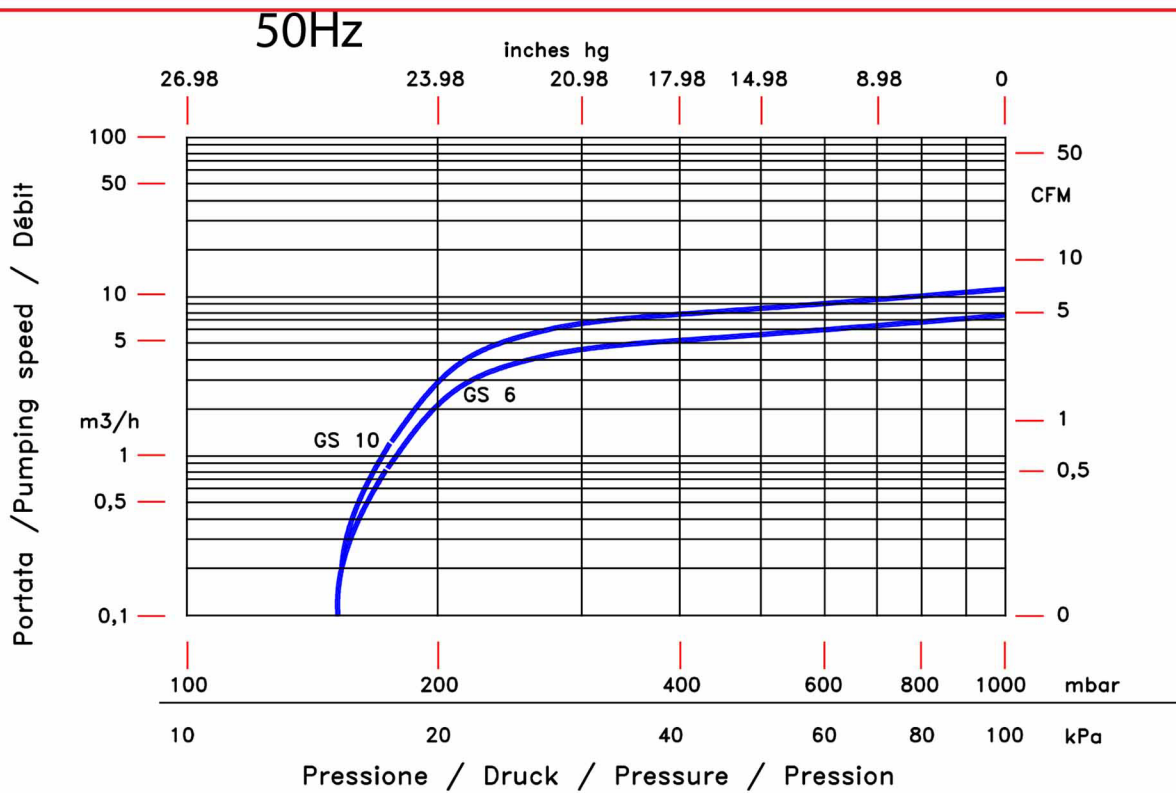

			Tipo di pompa/Frequenza Pump type/Frequency			
			GS 6 50Hz	GS 6 60Hz	GS 10 50Hz	GS 10 60Hz
Portata nominale	<i>Displacement</i>	m ³ /h	7,4	8,8	11	13,2
Vuoto finale	<i>Ultimate vacuum</i>	mbar	150	150	150	150
Rumorosità media	<i>Noise level</i>	db (A)	60	62	62	64
Tensione standard	<i>Standard voltage</i>	V	230/400	460	230/400	460
Potenza motore	<i>Motor power</i>	kW	0,55	0,55	0,55	0,55
Velocità di rotazione	<i>R.P.M.</i>	g/1'	1450	1750	1450	1750
Peso	<i>Weight</i>	kg	15	15	17	17