

			Tipo di pompa/Frequenza Pump type/Frequency	
			GS 100 / 50Hz	GS 100 / 60Hz
Portata nominale	<i>Displacement</i>	m ³ /h	100	120
Vuoto finale	<i>Ultimate vacuum</i>	mbar	150	150
Rumorosità media	<i>Noise level</i>	db (A)	75	76
Tensione standard	<i>Standard voltage</i>	V	230/400	460
Potenza motore	<i>Motor power</i>	kW	4	5,5
Velocità di rotazione	<i>R.P.M.</i>	g/1'	1450	1750
Peso	<i>Weight</i>	kg	97	97

Pompa tipo GS 100

Pump type GS 100

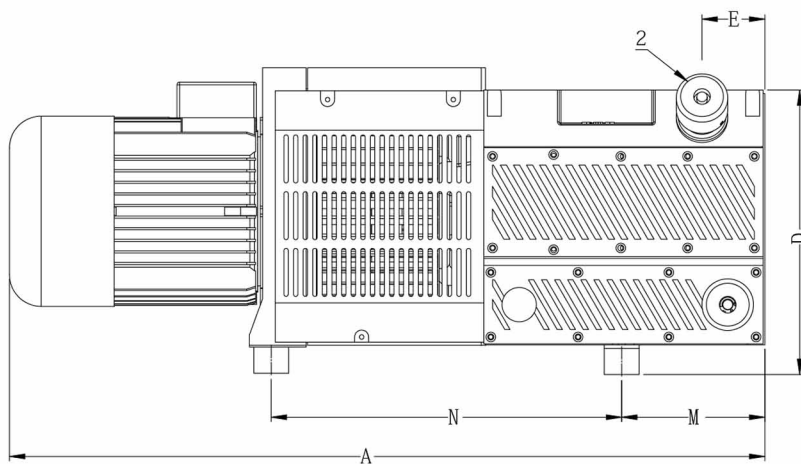
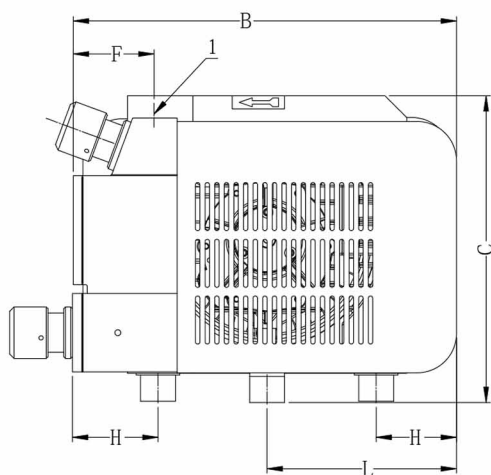

1 Aspirazione
2 Valvola regolazione
vuoto

1 Suction
2 Vacuum regulation
valve

	Dimensioni (mm) Dimension (mm)									
GS	A	B	C	D	E	F	H	L	M	N
100	865	439	351	326	72	92	98	217	164	401

Disponibile anche nella versione compressore
Pump is available also as compressor version