

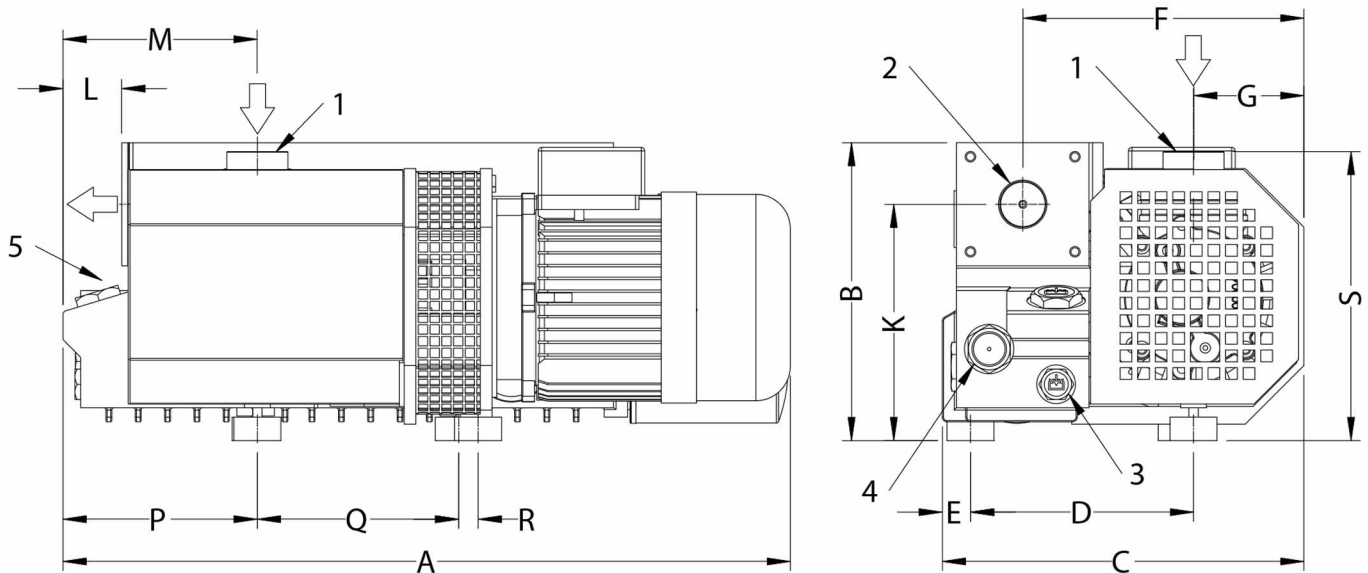

# Pompa tipo GP-GP/M 45-65

## Pump type GP-GP/M 45-65



- 1 Aspirazione
- 2 Scarico
- 3 Tappo scarico olio
- 4 Spia livello olio
- 5 Tappo carico olio

- 1 Suction
- 2 Discharge
- 3 Oil discharge plug
- 4 Oil sight glass
- 5 Oil fill up plug

	Dimensioni (mm) Dimension (mm)													
GP-GP/M	A	B	C	D	E	F	G	K	L	M	P	Q	R	S
45	619	254	308	190	24	239	94	201	50	165	165	171	16	246
65	684	254	308	190	24	239	94	201	50	165	165	171	56	246