

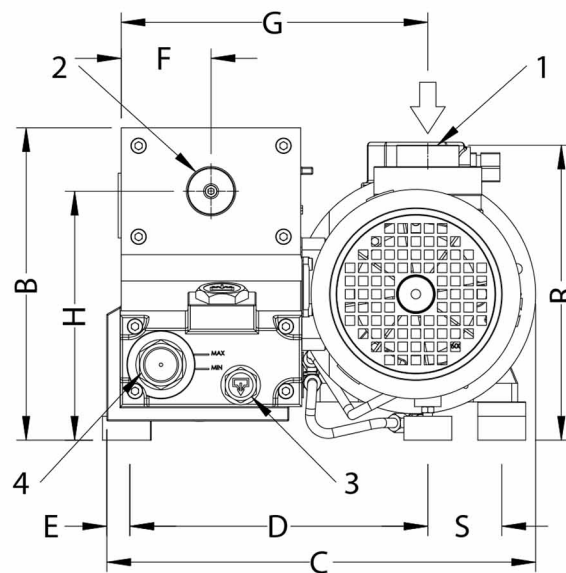

# Pompa tipo GP-GP/M 45K-65K

## Pump type GP-GP/M 45K-65K

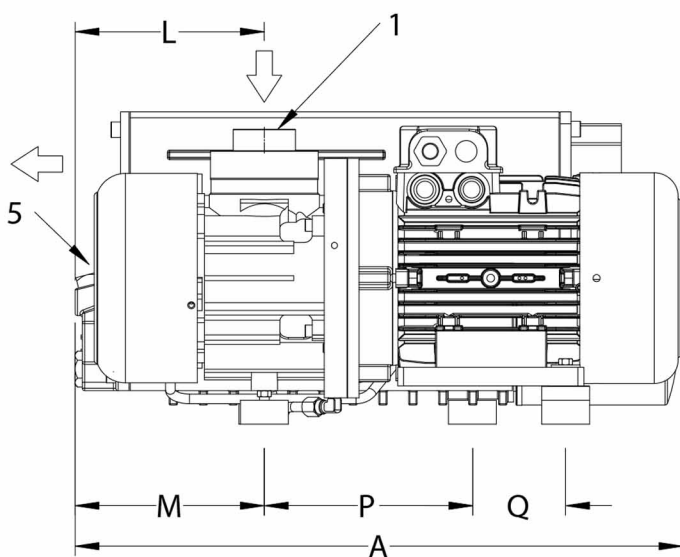

- 1 Aspirazione
- 2 Scarico
- 3 Tappo scarico olio
- 4 Spia livello olio
- 5 Tappo carico olio

- 1 Suction
- 2 Discharge
- 3 Oil discharge plug
- 4 Oil sight glass
- 5 Oil fill up plug

	Dimensioni (mm) Dimension (mm)													
GP-GP/M	A	B	C	D	E	F	G	H	L	M	P	Q	R	S
45K	507	261	358	249	19	75	256	208	158	158	174	77	246	62
65K	545	261	358	249	19	75	256	208	158	158	174	117	246	62